

ACCESSORY SETUP INSTRUCTION

REAR SPROCKET -- PN 6CUV-801610-6000

VALID FOR: CF700-2

BEFORE YOU BEGIN: Read and understand the instructions before starting any work. Make sure that all parts are ready and that you have all the tools required for assembly.

NOTE: CFMOTO shall not be liable for any damage caused by incorrect assembly. CFMOTO recommends that all original accessories be assembled by an authorized CFMOTO dealer.

Before assembly, park the vehicle on a flat surface, put the transmission gear into Park (P) and turn off the key switch.

Zhejiang CFMOTO Power Co., Ltd. All rights reserved. Reproduction of this document, even in part, as well as copying of all kinds, is permitted only with the express written permission of the copyright owner.

MEANING OF SYMBOLS

 - Indicates information with more details or tips.

 - Indicates information of warning or danger.

PARTS LIST:

ITEM	PART NAME	PART NUMBER	QTY.	REMARK
1	REAR SPROCKET	6GUV-801610-6000	1	

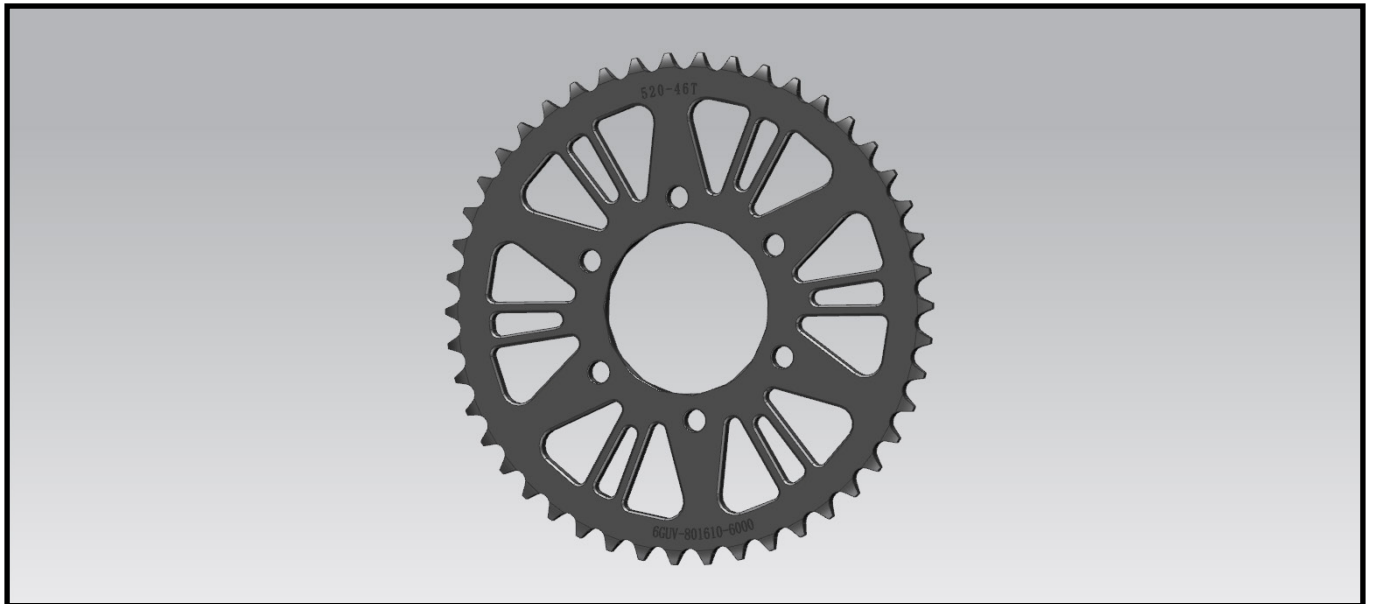

TOOL LIST:

ITEM	DESCRIPTION	QTY.	REMARK
1	13mm SOCKET	1	Recommended tools
2	23mm SOCKET	1	
3	10mm SOCKET	1	
4	LONG NOSE PLIERS	1	
5	4mm ALLEN WRENCH	1	

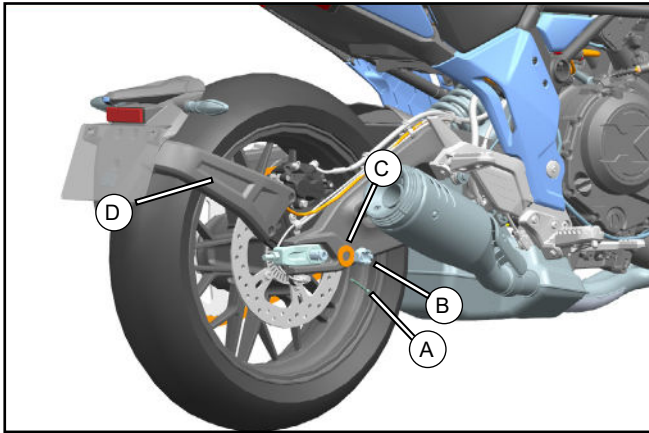

// Remove the rear fender (D), cotter pin (A), nut (B), washer (C) in turn.

i » Fix the motorcycle on the motorcycle service stand.

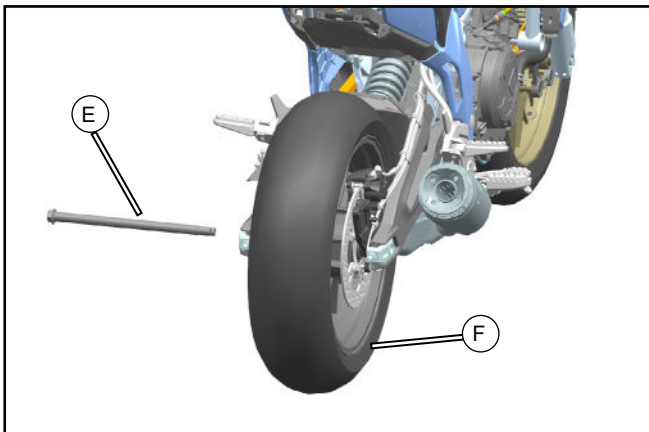

// Pull out the rear wheel shaft (E) then remove the rear brake caliper and take out the rear wheel (F).

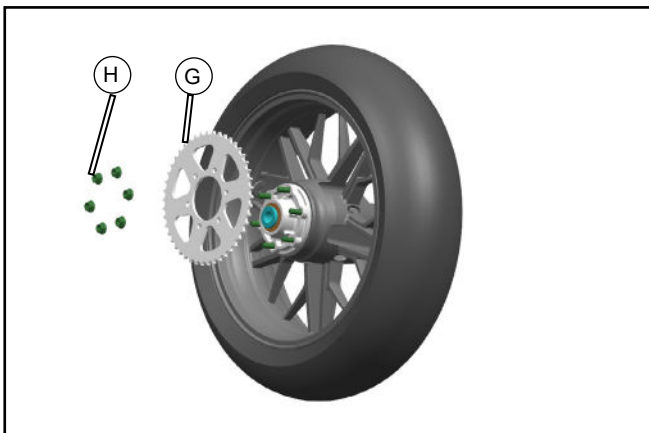

// Remove the original rear sprocket (G).

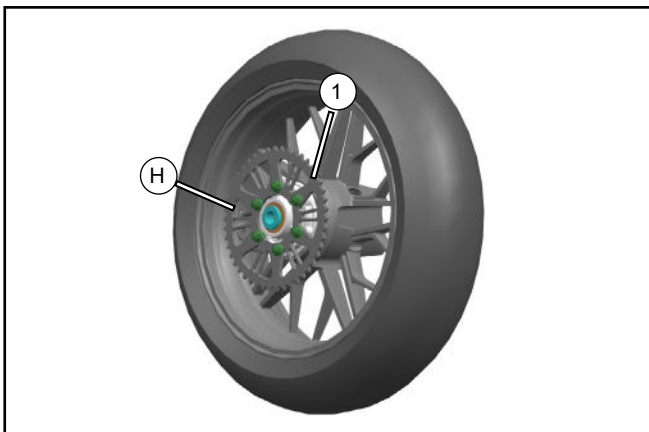

// Install the new rear sprocket (1) and tighten with nut (H).

i » Apply some thread lock sealant to the bolts.

ASSEMBLY and INSTALLATION

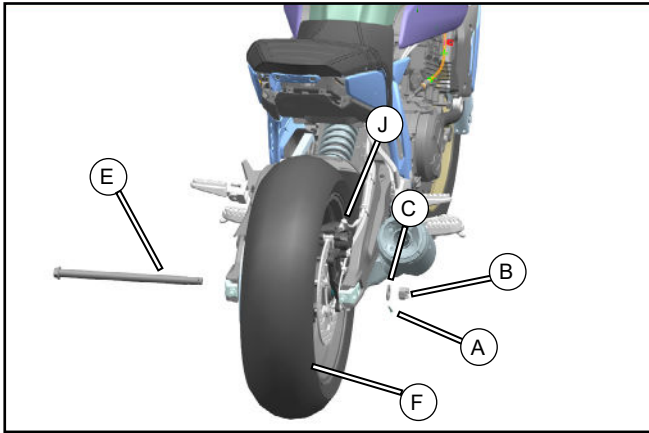

- // Install the rear wheel (F) with the rear brake caliper (J) into the installation position.
- // Install the rear wheel shaft (E), washer (C), nut (B), and cotter pin (A) in turn.

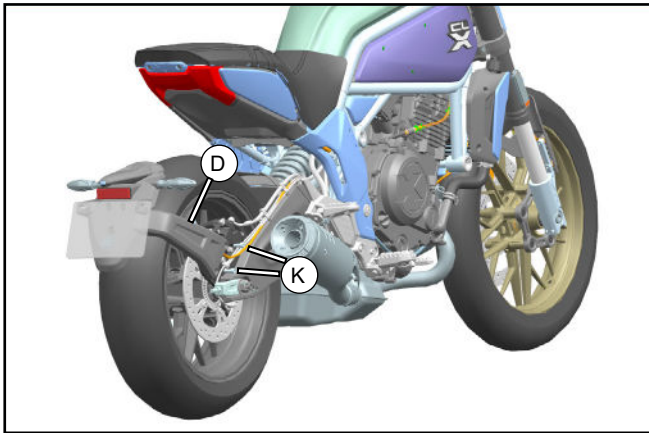

- // Install the rear fender (D) and tighten with bolts (K).